



ASIAN LE MANS SERIES COMMITTEE



TO: Teams

CATEGORY: LMP2 LMP2 Am LMP3 GT3 GT Cup

DECISION N°: Asian_2021_D0009_GT3_BOP ABUD

DATE: 17/02/2021

FROM: The Asian Le Mans Series Committee

SUBJECT: Balance of performance for the Abu Dhabi Competition

APPLICABLE REGULATION

Article 6.3.5 2021 Asian Le Mans Series Sporting Regulations

DECISION

Please find below on page 2/3 the GT3 BOP table.

PERIOD OF VALIDITY/APPLICATION OF THE DECISION

This decision comes into effect:

- with immediate application**
- from:

And is applicable:

- until further notice**
- for the mentioned event(s) only



ASIAN LE MANS SERIES BALANCE OF PERFORMANCE



Version: 21-3

GT3			CHASSIS			ENGINE				COMMENTS
HOMOLOGATION NUMBER FIA	MANUFACTURER	MODEL NAME	CAR WEIGHT (kg)			RESTRICTOR DIAMETER (mm)				
			previous (1)	adjust. (2)	final	# Restrictors	previous (1)	adjust. (2)	final (*)	
GT3-042	MERCEDES AMG	GT3	+1325 kg	-	+1325 kg	2	34,5 mm	-	34,5 mm	
GT3-043	BMW	M6 GT3	+1315 kg	-	+1315 kg	-	-	-	-	See Boost Table
GT3-044	FERRARI	F488	+1300 kg	-	+1300 kg	-	-	-	-	See Boost Table
GT3-050	PORSCHE	911 GT3-R	+1275 kg	+15 kg	+1290 kg	2	41,5 mm	-	41,5 mm	
GT3-051	ASTON MARTIN	VANTAGE GT3	+1300 kg	-	+1300 kg	-	-	-	-	See Boost Table
GT3-052	MCLAREN	720S-GT3	+1275 kg	-	+1275 kg	-	-	-	-	See Boost Table

HOMOLOGATION	GT3-043
MANUFACTURER	BMW
MODEL NAME	M6 GT3
RPM	MAX BOOST RATIO
4000	1,76
4500	1,84
5000	1,92
5500	1,96
6000	1,92
6500	1,73
7000	1,60
>/7100	1,43

HOMOLOGATION	GT3-044
MANUFACTURER	Ferrari
MODEL NAME	488
RPM	MAX BOOST RATIO
4000	1,47
4500	1,51
5000	1,55
5500	1,58
6000	1,60
6500	1,58
7000	1,53
7500	1,45
>/7600	1,37

HOMOLOGATION	GT3-051
MANUFACTURER	Aston Martin
MODEL NAME	Vantage GT3
RPM	MAX BOOST RATIO
4000	1,62
4500	1,67
5000	1,75
5500	1,81
5750	1,82
6000	1,84
6250	1,83
6500	1,83
6750	1,77
7000	1,72
7200	1,63
>/7300	1,40

HOMOLOGATION	GT3-052
MANUFACTURER	Mclaren
MODEL NAME	720S
RPM	MAX BOOST RATIO
4000	1,78
4500	1,75
5000	1,72
5500	1,70
6000	1,62
6500	1,56
7000	1,45
7500	1,40
8000	1,34
>8100	1,12

(*) Technical drawings of engine air restrictors must be supplied to ACO. Only ACO approved engine air restrictors are allowed.

(1): the previous value is referring to the previous BOP

(2): the adjustments shown are related to the changes done for this BOP publication



LED Boost control strategy
V10 GT3

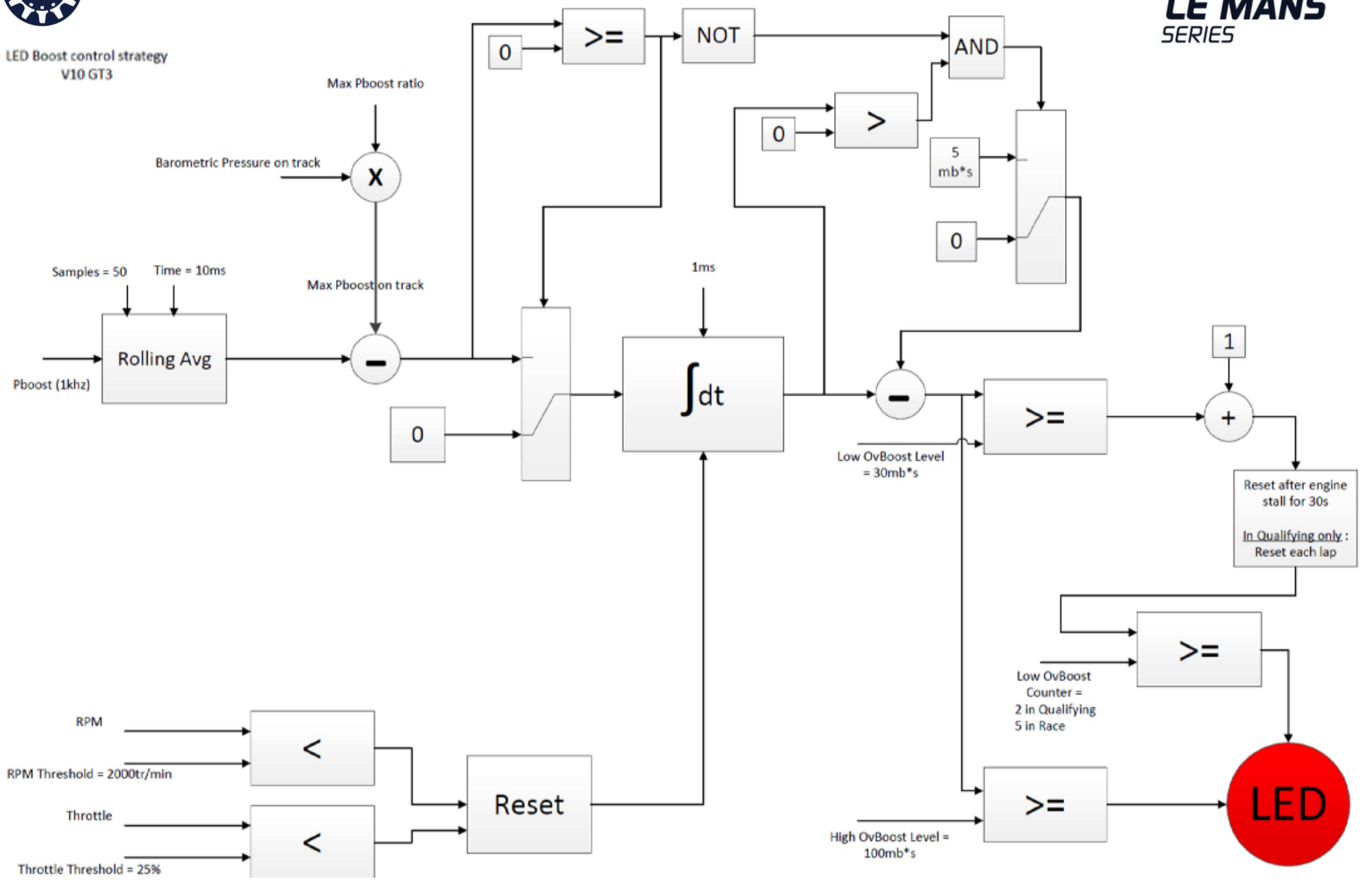

Reset after engine stall for 30s
In Qualifying only :
Reset each lap

Low OvBoost Counter =
2 in Qualifying
5 in Race

